

# 7215-7226-7227 INT/ 7215F-7226F-7227F INT

## 3/4" Offset intermediate pivot (fire and non-fire rated models)

NFPA 80, Section 3-3.8 requires intermediate pivot on some fire door applications, consult product support. Use for door heights over 7'0" and one every 2'6" as needed.

- 7215-7226-7227 intermediate pivot is used with 7215, 7226, and 7227 offset pivots
- 7215F-7226F-7227F intermediate pivot is used with 7215F, 7226F, and 7227F offset pivots; fire rated
- Use for door weight over the pivot set limit. Use one additional pivot for every additional 100 pounds
- Recommended for use with 1 3/4" minimum door thickness, with 1/8" bevel in 2"
- Handed LH or RH

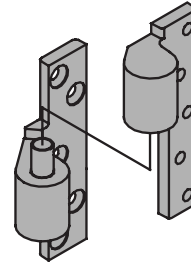

### Specifications

Material substrate	<ul style="list-style-type: none"> <li>7215-7226-7227 - Made from cast brass</li> <li>7215F-7226F-7227F - Made from 304 series stainless steel</li> </ul>
Certifications	<ul style="list-style-type: none"> <li>7215-7226-7227 - Meets ANSI/BHMA A156.4 C07321</li> <li>7215-7226-7227 - UL10C Listed (20 min)</li> <li>7215F-7226F-7227F - Meets ANSI/BHMA A156.4 C07371</li> <li>7215F-7226F-7227F - UL10C Listed (3 hour)</li> </ul>

### 7215-7226-7227 INT Finishes

BHMA	Description	Substrate	Finish
605	Bright brass	Brass	US3
606	Satin brass	Brass	US4
612	Satin bronze	Brass	US10
613	Oil rubbed bronze	Brass	US10B
619	Satin nickel	Brass	US15
622	Matte black	Brass	BLK
625	Bright chrome	Brass	625
626	Satin chrome	Brass	626
-	Aged bronze	Brass	643e/716
689	Aluminum painted	Brass	SP28
691	Bronze painted	Brass	SP10
695	Dark bronze painted	Brass	SP313/US10BE
706	Brass painted	Brass	SP4

### 7215F-7226F-7227F INT Finishes

BHMA	Description	Substrate	Finish
629	Bright stainless	Stainless steel	US32
630	Satin stainless	Stainless steel	US32D
631	Matte black	Stainless steel	BLK
632	Bright brass	Stainless steel	US3
639	Satin bronze	Stainless steel	US10
-	Aged bronze	Stainless steel	643e/716
689	Aluminum painted	Stainless steel	SP28
691	Bronze painted	Stainless steel	SP10
695	Dark bronze painted	Stainless steel	SP313/US10BE
706	Brass painted	Stainless steel	SP4

For other colors, consult factory.

