

A
Hinges & Pivots

B8
Pulls & Plates

C
Flush Bolts & Coordinators

D
Latches, Catches & Bolts

E
Stops

F
Exterior Hardware

G
Miscellaneous Hardware



8311 Pull plate

Available mounting – Standard or F see page B15
Pulls have 1/4-20" mounting.

8300 Plate
3-1/2" x 15"
4" x 16"
6" x 16"

8111-5 Pull
5-1/8" centers

Finishes brass

US Number	US3	US4	US10	US10B	US26	US26D*
BHMA	605	606	612	613	625	626

Finishes stainless steel

US Number	US32D*
BHMA	630

Finishes aluminum

US Number	US28
BHMA	628

* Available with Antimicrobial Coating, use suffix AM

9100 Series Push Bar and Pull Combinations

- Available in brass, stainless steel or aluminum.
- Standard fasteners furnished for 1-3/4" thick doors. Specify door thick if other than standard.
- Special lengths are available, contact customer service.

See page B17 for special mounting requirements.

Caution – the length of the pushbar should not interfere with the door jamb or cause a pinch point.

9100HD Push Bar

Available mounting – NO or NS see page B17
with heavy duty 3/8-16" mounting



Product No.	Projection	Clearance	Center to Center	Overall Length
9100-28	2-1/2"	1-1/2"	28"	29"
9100-33	2-1/2"	1-1/2"	33"	34"

Special lengths available, consult factory

Finishes brass

US Number	US3	US4	US10	US10B	US15	US26	US26D*
BHMA	605	606	612	613	619	625	626

Finishes stainless steel

US Number	US32	US32D*
BHMA	629	630

* Available with Antimicrobial Coating, use suffix AM

Mounting

- All mounting hardware is for standard 1-3/4" door.
- Consult Customer Service if other than standard.

Type Standard Mount

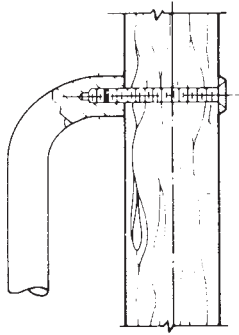

Standard Mounting

- (2) 3/8-16 x 2-1/4" brass, flat head machine screws; plate to match.
 - (2) 3/8-16 countersunk washers; plated to match
- Note: 8102HD and 8105 have (2) 5/16-18 x 2-1/2" machine screws
 -Options: (2) 5/16 countersunk washers

Type G Mount

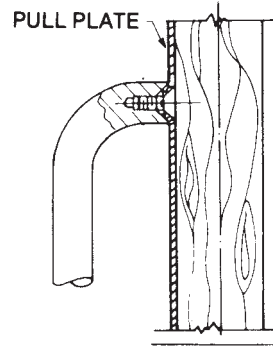

Concealed Pull Plate Mounting

- Available only for 8302, 8303, 8311 Pull Plates.
- (2) 3/8-16 x 5/8" steel flat head machine screws; zinc plated.
- Pull mounts directly onto plate.
 Plate is attached to door by 6 screws.
 Note: 8302 has (2) 5/16-19 x 5/8" steel flathead zinc plated screws

Type F Mount

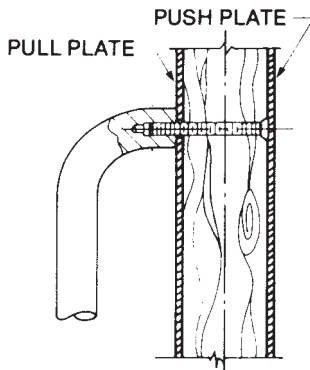

Wood Doors Concealed Pull Mounting With Push Plate

- (2) 2-1/4" steel flat head machine screws; zinc plated.
- Available only for 8102HD, 8103HD, 8105, 8111, 8302, 8303, 8305 and 8311. Plate on opposite side of door must be ordered separately.
- Note: 8102HD, 8302 will have 5/16-18
 8105, 8111, 8305, 8311 will have 1/4-20
 8103HD, 8303 will have 3/8-16"

Type H-I-L Mount

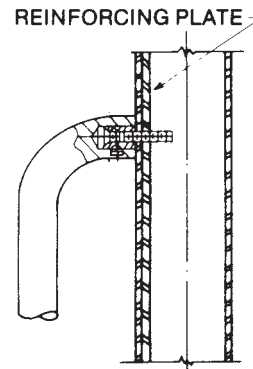

Reinforced Hollow Metal Door Concealed Pull Mounting

- Available only for 8102, 8103, 810EZ or wood door pulls, 8302, 8303 pull plates and 9264, 9265, 9266 and 9267 long door pulls.
- (2) Steel screw sleeves; zinc plated.
 - (2) Steel countersunk trim head machine screw; zinc plated for reinforced metal door.
 - (2) Steel countersunk trim head steel metal screw; zinc plated for wood doors.
- Note: 8102HD and 8302 will have 5/16-18"
 8103HD, 8103EZHD, 8303 will have 3/8-16"

Mounting

- All mounting hardware is for standard 1-3/4" door.
- Consult Customer Service if other than standard.

Type K Mount

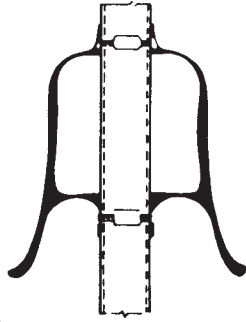

Back to Back Pull Mounting

Available only for 8121-5 Pulls.

- (4) Steel screw sleeve nuts; steel zinc plated.
 - (8) No. 8-32 x 1" brass oval head machine screws; plated to match.
- Pulls furnished in pairs (PR).

Mounting for 8103EZ, 8190, 9100, 9103EZ, 9190 and 9264, 9265, 9266 and 9267 long door pulls.

• All mounting hardware is for standard 1-3/4" door.

• Consult Customer Service if other than standard.

Type J/N Mount

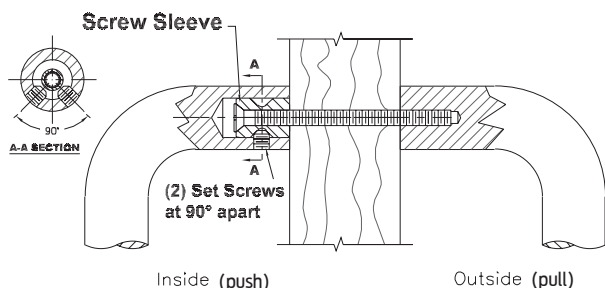

Back to Back "Two-Anchor"

Wood or Metal Door

Available only for 8103EZHD, 8190HD, 9100HD push/pull combinations and 9264, 9265, 9266 and 9267 long door pulls.

- (2) 3/8-16 x 2-3/4" steel countersunk trim head machine screws with (4) set screws for maximum anchoring force.
- (2) Steel screw sleeves; zinc plated.

Type NS-Standard Push/Pull Mounting

Type N & Standard

Pushbar to Pull

- (1) 3/8 - 16 X 3" steel countersunk trim head machine screws with (2) set screws.
- (1) steel screw sleeve, zinc plated.

Free End Pushbar & Pull

- (2) 3/8 - 16 X 2-1/4" brass, oval head mach screws; plated to match.
- (2) No. 14 countersunk washers; plated to match.

Type O Mount

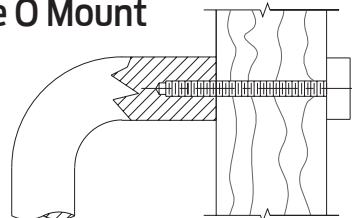

Decorative Blind Thru - Bolt

Wood or Metal Door

Available only for 8103EZHD, 8190HD and 9100HD Series Push/Pull Combinations.

- (2) 3/8-16 x 2-1/4" blind thru - bolts; plated to match.

Type NO Push/Pull Mounting

Type N & Type O

Pushbar to Pull

- (1) 3/8 -16 X 3" steel countersunk trim head machine screws with (2) set screws.
- (1) steel screw sleeve, zinc plated.

Free End Pushbar & Pull

- (2) 3/8 - 16 X 2-1/4" blind thru-bolts; plated to match.

Type P Mount

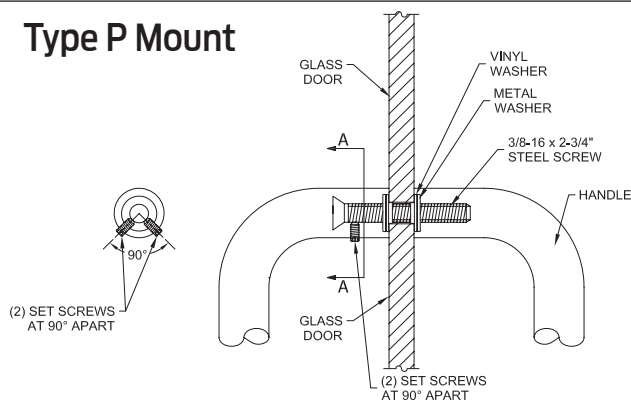

1/2" Glass Door

Available only for 8103EZHD, 8190HD, 9100HD, 9265 and 9266 long door pulls.

- (2) 3/8-16 x 2-1/4" steel countersunk trim head machine screws with (4) set screws for maximum anchoring force.
- (2) Steel screw sleeves; zinc plated
- (2) Metal and Vinyl washers

A Hinges & Pivots
 B17 Pulls & Plates
 C Flush Bolts & Coordinators
 D Latches, Catches & Bolts
 E Stops
 F Exterior Hardware
 G Miscellaneous Hardware